

CLEVELAND
STEEL
CONTAINER
CORPORATION



UN
CLOSING
INSTRUCTION
MANUAL

Date: 04/20/2006



CLEVELAND STEEL CONTAINER CORPORATION

1840 Enterprise Parkway Twinsburg, Ohio 44087

April 20, 2006

To Our Customers and Distributors:

Cleveland Steel Container Corporation is required by 49 CFR (The Code of Federal Regulations, Title 49 – Transportation), to **notify** all of our customers and distributors using Cleveland Steel Container's UN packaging that they must comply with our UN Closing Instructions.

The actual terminology in 49 CFR, §178.2(c) Notification, clearly states that the manufacturer or other person certifying compliance with the requirements of Part 178, and each subsequent distributor of that packaging shall-

- (1) Notify in writing each person to whom that packaging is transferred-
 - (i) Of all requirements in Part 178 not met at the time of transfer, and
 - (ii) Of the type and dimensions of any closures, including gaskets, needed to satisfy performance test requirements;
- (2) Retain copies of each written notification for at least one year from date of issuance; and
- (3) Make copies of all written notification available for inspection by a representative of the Department.

The Pipeline and Hazardous Materials Safety Administration (PHMSA) is proposing rulemaking to require fillers/shippers to retain copies of closing instructions provided to them by industrial packaging manufacturers.

In the attached accompanying manual, you will find the complete set of Cleveland Steel Container Corporation's UN Closing Instructions. In addition, we have included in the manual, a table of contents and matrix that will help you chose which UN Closing Instructions are required based on the type of UN packaging that you purchase.

Also included in the manual is an acknowledgment form that must be signed in accordance with 49 CFR, §178.2(c) Notification. We ask that an authorized representative of your company sign and date the form, and fax it back to our Corporate Office to the attention of Sue Bush at 330-405-3220 by November 28, 2005 .

To fulfill the requirement of compliance with 49 CFR, §178.2(c) Notification, Cleveland Steel Container will retain a copy of the signed acknowledgement form on file at our Corporate Office, such that it can be made available for inspection by a representative of the Department. If you have any questions please feel free to contact your Regional Sales Manager.

Sincerely yours,

Don Dulin
Vice President – Technical Services



CLEVELAND STEEL CONTAINER CORPORATION

1840 Enterprise Parkway Twinsburg, Ohio 44087

**Receipt of UN Closing Instructions
Acknowledgement Form**

I, _____, acknowledge that I have received, read, printed, and distributed
(Please Print Name)

to the appropriate Hazmat personnel responsible for UN Compliance,

CLEVELAND STEEL CONTAINER CORPORATION'S UN CLOSING INSTRUCTION MANUAL

in accordance with 49 CFR, §178.2(c) Notification.

I understand that the material in this manual is subject to change and/or revision.

Company Name

Authorized Representative Signature

Date

Please fax a signed copy to **Sue Bush** at **330-405-3220**, or mail a signed copy to the above address.



Cleveland Steel Container U.N. Closing Instructions

Table of Contents

Closing Instruction #	Closing Instruction Name	Pages	CSC Form Number
1	Delpak Bolt Ring Closing Instructions	1,2	QA-FM-L272
2	Combination 4B Cylinder Closing Instructions	3,4	QA-FM-L268
3	Delpak Leverlock Closing Instructions	5,6	QA-FM-L271
4	Delpak Lug Cover Closing Instructions	7,8	QA-FM-L270
5	Leverlock(RU/RS) Closing Instructions	9	QA-FM-L257
6	Bolt Ring Closing Instructions	10	QA-FM-L258
7	Openhead Closing Instructions	11,12	QA-FM-L251
8	Rieke® Drum Fitting Closing Instructions	13	QA-FM-L255
9	Rieke® FlexSpout® Closing Instructions	14	QA-FM-L253
10	Screw Cap Closing Instructions	15	QA-FM-L252
11	Tri-Sure® Drum Fitting Closing Instructions	16	QA-FM-L256
12	Tri-Sure® UNI-GRIP® Spout Closing Instructions	17	QA-FM-L254
13	UNi-Pak Cradle Closing Instructions	18,19	QA-FM-L250
14	UNi-Pak Liner Closing Instructions	20,21	QA-FM-L273
15	UNi-Pak Tray with Scholle Bag Closing Instructions	22,23	QA-FM-L266
16	UNi-Pak Tray Closing Instructions	24,25	QA-FM-L267
17	Stolz HZ60 Screw Cap Closing Instructions	26	QA-FM-L274
18	Leverlock(RU-1) Closing Instructions	27	QA-FM-L275



Cleveland Steel Container-UN Closing Instruction Matrix

			UN CLOSING INSTRUCTION FORM #																		
Pail Type	Cover	Fitting	QA-FM-L272	QA-FM-L268	QA-FM-L271	QA-FM-L270	QA-FM-L257	QA-FM-L258	QA-FM-L251	QA-FM-L255	QA-FM-L253	QA-FM-L252	QA-FM-L256	QA-FM-L254	QA-FM-L250	QA-FM-L273	QA-FM-L266	QA-FM-L267	QA-FM-L274	QA-FM-L275	
Open-Head Pail	UN Lug Cover	None							X												
		Rieke® FlexSpout®							X		X										
		Tri-Sure® UNI-GRIP® Spout								X					X						
		Rieke® Drum Fitting								X	X										
		Tri-Sure® Drum Fitting								X				X							
		Metal Screw Cap								X			X								
		Stolz HZ60 Screw Cap								X										X	
		Delpak poly bottle insert				X				X											
	UN Liner Cover	CDF HDPE Cradle								X						X					
		CDF HDPE Liner								X							X				
		CDF HDPE Tray								X									X		
		CDF HDPE Tray w/ Scholle bag								X								X			
	UN RingSeal Cover	RU or RS LeverLock Ring					X														
		RU-1 LeverLock Ring																			X
		Bolt Ring with Delpak Poly Bottle	X																		
		Lever Lock Ring with Delpak Poly Bottle			X																
		Rieke® FlexSpout®				X					X										
		Tri-Sure® UNI-GRIP® Spout				X									X						
		Metal Screw Cap				X							X								
		Rieke® Drum Fitting				X					X										
Tri-Sure® Drum Fitting					X								X								
Bolt Ring							X														
LeverLock Ring with 4B Cylinder		X																			
Tighthead Pail	Tighthead Top	Rieke® FlexSpout®									X										
		Tri-Sure® UNI-GRIP® Spout													X						
		Rieke® Drum Fitting									X										
		Tri-Sure® Drum Fitting												X							
		Metal Screw Cap											X								
		Rieke® FlexSpout® & Metal Screw Cap										X	X								
		Tri-Sure® UNI-GRIP® Spout & Metal Screw Cap											X		X						
		Rieke® Drum Fitting & Metal Screw Cap									X		X								
		Tri-Sure® Drum Fitting & Metal Screw Cap											X	X							



Closing Instructions for The Delpak Bolt Ring

CSC Form # QA-FM-L272 Rev. 2 Date 08/07/02

Page 1

(UN RingSeal with R5 Bolt Ring)

1. Verify that the EPDM gasket is in place on the 2-inch buttress plug.
2. Tighten the buttress plug to a torque value of 250 in-lbs. using a preset calibrated torque wrench.
3. Place the HDPE filled liner into the empty steel overpack.
4. Place the steel RingSeal cover on the overpack.
5. Position the Bolt Ring around the top of the steel overpack with the eyes of the Ring positioned down below the curl of the overpack. For proper closure, the Bolt Ring should cover the lip of the cover and the curl of the overpack.
6. Slide the 1/4" bolt through the eyes of the Ring.
7. Place the nut at the end of the bolt and torque to 50 in-lbs.

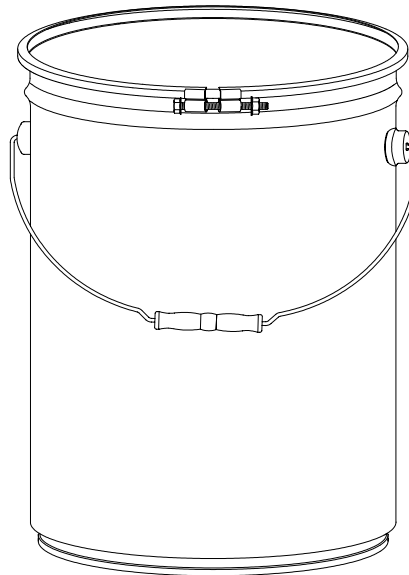

Signature: _____

Michael J. De...



Closing Instructions for The Delpak Bolt Ring

CSC Form # QA-FM-L272 Rev. 2 Date 08/07/02

Page 2

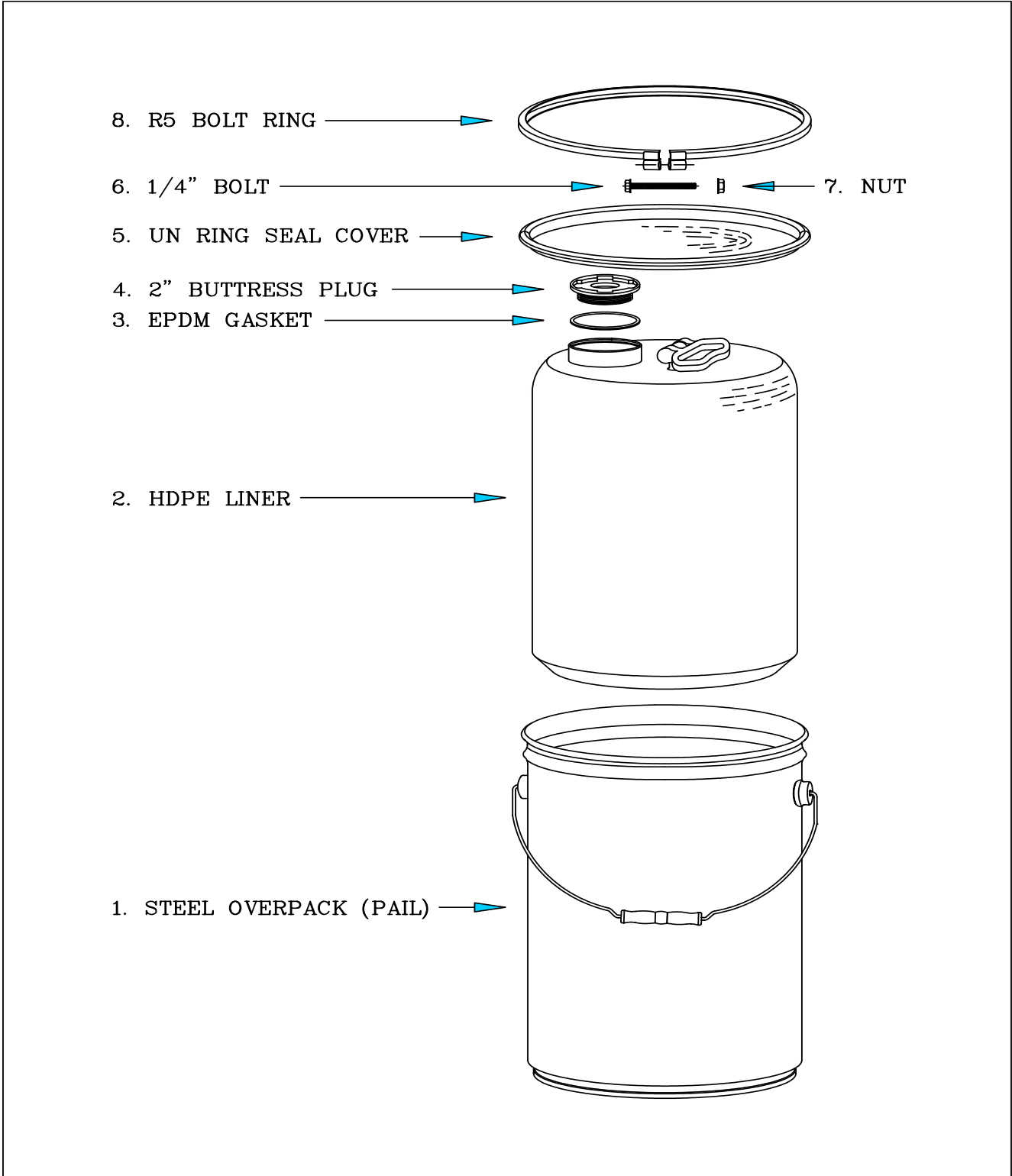



Combination 4B Cylinder Closing Instructions

CSC Form # QA-FM-L268

Rev. 4

Date 06/10/04

Page 3

- 1) Insert a vermiculite bag in the bottom of the empty pail. The bag should be large enough to cover the entire bottom surface of the pail.
- 2) Insert the stainless steel 4B Cylinder upright into the pail as shown. The Cylinder should be placed directly in the center at the bottom of the pail on top of the vermiculite bag.
- 3) Completely surround the entire perimeter of the Cylinder with 2 bags of Vermiculite. When placing the bags around the cylinder, be sure not to displace the Cylinder from the center position in the pail.
- 4) Place a bag of vermiculite over the top of the cylinder. The bag should be large enough to cover the top portion of the pail.
- 5) Place the Ring Seal Cover on top of the pail. Do not force the cover onto a pail if it is over-packed with Vermiculite. Forcing a cover onto an over-packed pail may cause damage to the cylinder.
- 6) **Proper Application of the Lever Lock Ring to the Pail:**
 - a) First place the cover on the pail and press downward along the edges and in the center to ensure that it is seated properly.
 - b) Open handle to widest margin, then slip ring over pail.
 - c) Orient the handle of the ring opposite the side seam of the pail or at 180° from the side seam.
 - d) Apply downward pressure to the cover and release the handle allowing the ring to slide onto the cover/curl edge. Make sure that the ring encompasses the cover/curl around the entire edge of the pail.
 - e) Move the handle clockwise by applying pressure until the handle is in the closed position.
 - f) Insert the tamper-evident clip through the slot in the handle. The clip should also pass through the loop attached to the body of the ring.
 - g) After it is locked, the ring should not be able to rotate or move. Any sliding of the ring could indicate an oversized ring.

Signature: _____



Combination 4B Cylinder Closing Instructions

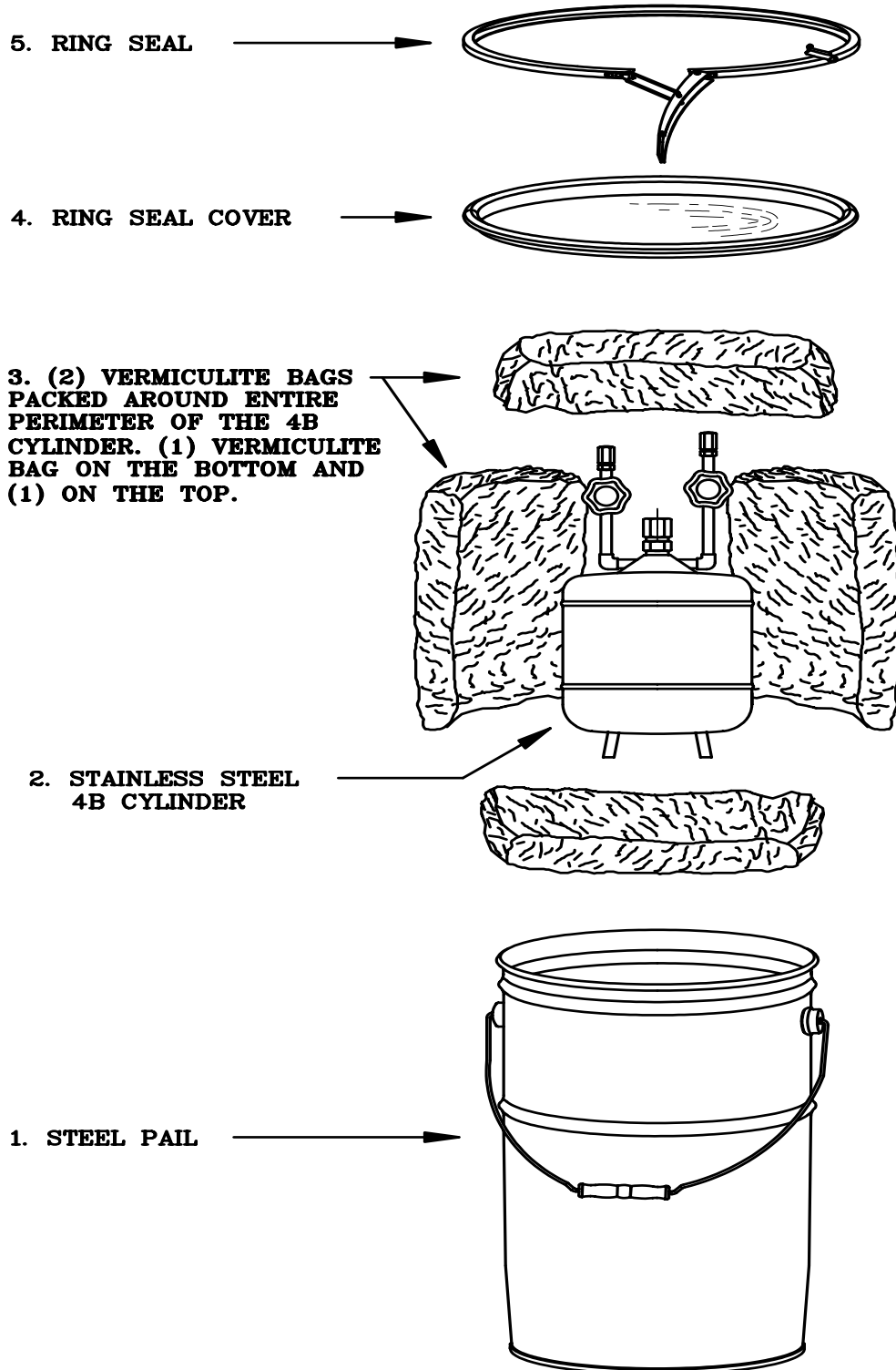



Closing Instructions for The Delpak Leverlock Ring

CSC Form # QA-FM-L271 Rev. 2 Date 08/07/02

Page 5

(UN RingSeal with RU Leverlock Ring)

1. Verify that the EPDM gasket is in place on the 2-inch buttress plug.
2. Tighten the buttress plug to a torque value of 250 in-lbs. using a preset calibrated torque wrench.
3. Place the HDPE filled liner into the empty steel overpack.
4. Place the steel RingSeal cover on the overpack.
5. Position the Leverlock Ring around the top of the steel overpack with the locking clip positioned up. For proper closure, the Leverlock Ring should cover the lip of the cover and the curl of the overpack.
6. Clamp Ring into place by pushing lever into closed position.
7. Rotate locking clip clockwise and push the eye of the locking clip through the groove of the lever, while at the same time, ensuring that the small tab at the end of the lever is tucked beneath the pocket at the center of the locking clip.

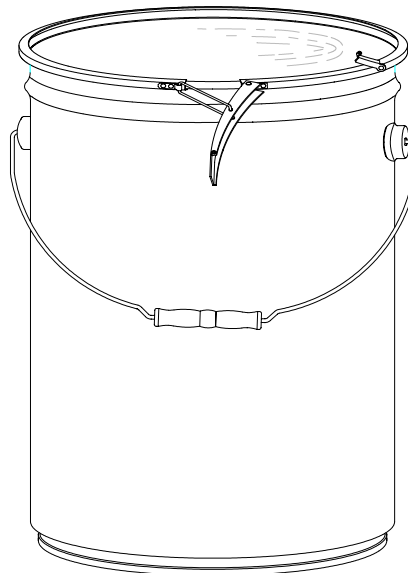

Signature: 



Closing Instructions for The Delpak Leverlock Ring

CSC Form # QA-FM-L271

Rev. 2

Date 08/07/02

Page 6

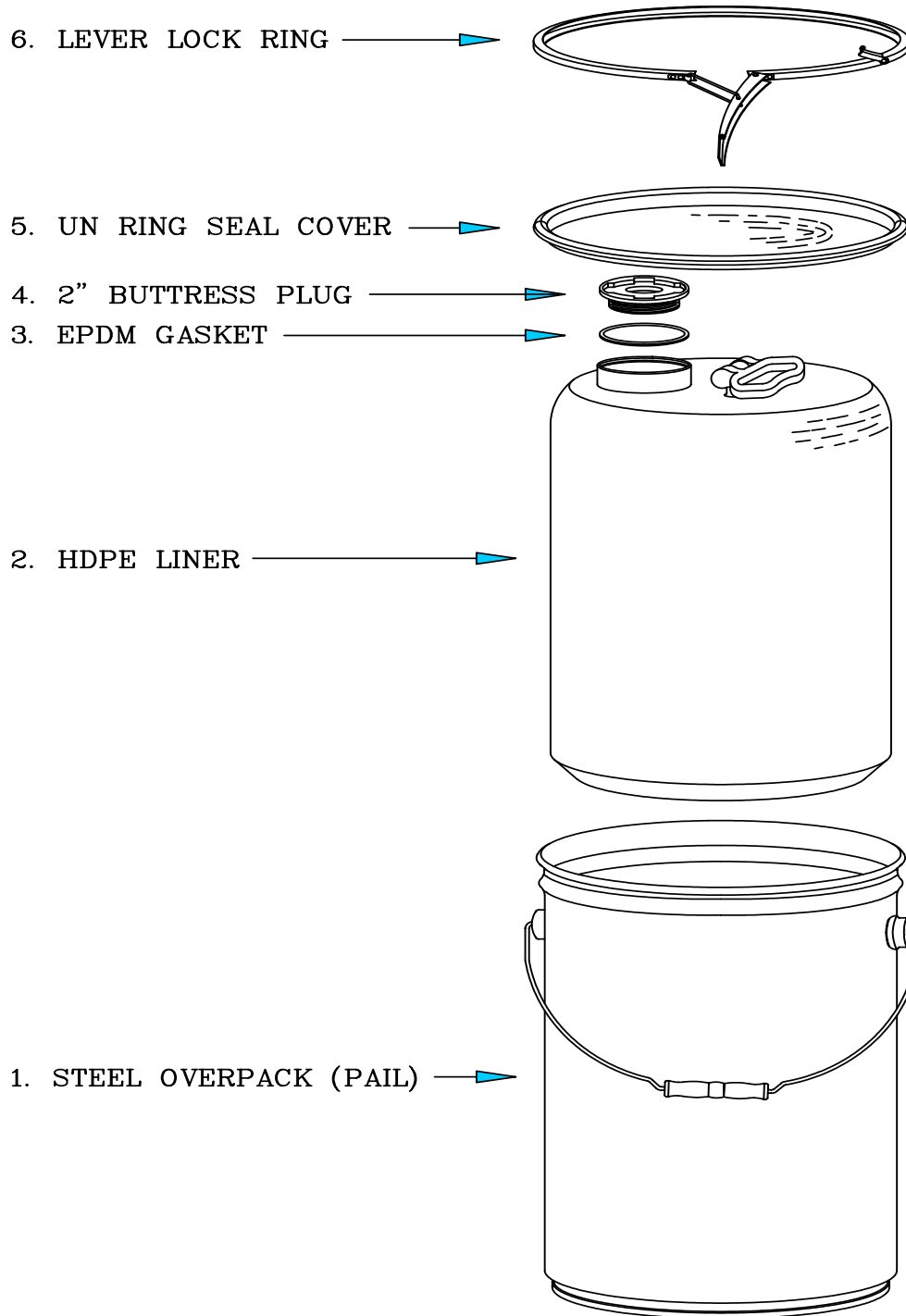



Closing Instructions for The Delpak Lug Cover

CSC Form # QA-FM-L270

Rev. 2

Date 08/07/02

Page 7

(UN Lug Cover)

1. Verify that the EPDM gasket is in place on the 2-inch buttress plug.
2. Tighten the buttress plug to a torque value of 250 in-lbs. using a preset calibrated torque wrench.
3. Place the HDPE filled liner into the empty steel overpack.
4. Place the UN lug cover on the pail.
5. Position the closing tool on top of the UN cover such that the jaws of the closing tool are centered between the lugs of the cover.
6. For Manual Hand Operated Closing Tool:
 - Press the handles down completely to the stops. Turn the tool 180 and repeat.
 - The lugs of the cover should be completely tucked under the curl of the pail.

For Pneumatic Semi-Automatic Tool:

- Connect air line to the closing tool. Adjust air pressure to desired setting. 80 psi is strongly suggested.
- Press the actuator buttons to crimp the cover.
- Release the buttons after jaws completely collapse lugs under the curl and come to a stop.

Cleveland Steel Container strongly suggests that all UN containers be closed using a Carando Machine Works Pneumatic Semi-Automatic Closing Tool.

Signature: _____

A handwritten signature in black ink, appearing to read "Michael J. De...". The signature is written over a horizontal line.



Closing Instructions for The Delpak Lug Cover

CSC Form # QA-FM-L270 Rev. 2

Date 08/07/02

Page 8

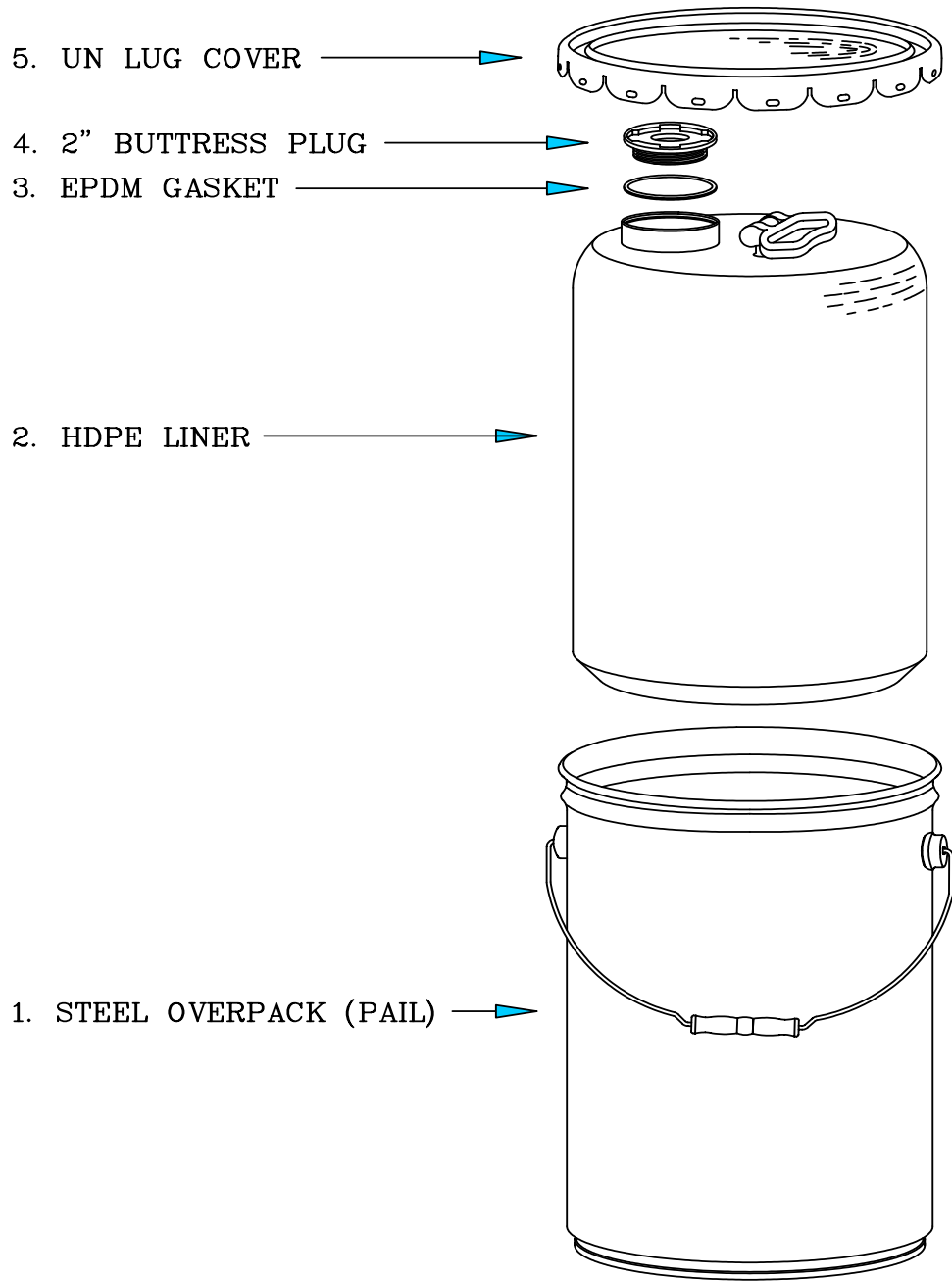

LeverLock(RU/RS) Closing Instructions

Form# QA-FM-L257

Rev. 6

Date: 12/07/09

Page 9

Proper Application of the RU or RS LeverLock Ring to the Pail

1. First place the cover on the pail and press downward along the edges and in the center to ensure that it is seated properly. See **Figure 1**.
2. Open leverlock ring to widest margin, then slip ring over pail. Be sure that the ring is placed on the pail such that it can be closed by moving the lever clockwise onto the ring. See **Figure 2**.
3. Orient the lever on the ring opposite the side seam of the pail or at 180° from the side seam.
4. Apply downward pressure to the cover and release the lever allowing the ring to slide onto the cover/curl edge. Be sure that the ring encompasses the cover/curl around the entire edge of the pail. See **Figure 3**.
5. Close the ring clockwise by applying pressure to the lever until it collapses onto the ring, as in **Figure 4**.
6. Insert the tamper-evident T-clip through the slot in the lever to hold the lever in place. The T-clip should also pass through the loop attached to the body of the ring.
*** A locking mechanism may be inserted into the eyelet of the latch to make tamper-evident.**
7. After it is locked, the ring should not be able to be rotated or moved. Any sliding of the ring could indicate an oversized ring.



Fig. 1



Fig. 2



Fig. 3



Fig. 4

Signature: 



Bolt Ring Closing Instructions

CSC Form # QA-FM-L258

Rev. 3

Date 08/07/02

Page 10

Proper Application of the Bolt Ring to the Pail

1. First place the cover on the pail and press downward along the edges and in the center to ensure that it is seated properly.
2. Take the ring in two hands with the bolt eyelets facing towards the installer.
3. Press one end of the ring up and the other down.
4. Orient the bolt eyelets of the ring opposite the side seam of the pail or at 180° from the side seam.
5. Set the low end of the ring on the pail lip so that it encompasses both the cover and the curl.
6. Work the ring around the cover/curl edge making sure that both the cover and curl are both encompassed by the ring the entire way around the pail.

***Note:** Applying downward pressure on the cover will make it easier to work the ring around the cover/curl edge.

7. With both hands, squeeze together the ends of the ring where the bolt eyelets connect to the ring.
8. Place a bolt through both eyelets and apply nut to the end.
9. Tighten the nut to the recommended torque of 50 inch pounds.
10. Check for proper fit and tightness of the ring by securing the pail and attempting to rotate or move the ring.
11. Any sliding of the ring could indicate an oversized ring or improper torque.

Signature: _____

A handwritten signature in black ink, appearing to read "Michael J. De..." with a stylized flourish at the end.



Open Head Closing Instructions

CSC Form # QA-FM-L251

Rev. 5

Date 06/10/04

Page 11

- 1) Determine that the pail/cover combination is the correct product code for the material being filled.
- 2) Place cover on pail with the eye of one of the lugs centered directly over the sideseam of the pail. Ensure that it is evenly seated around the curl of the pail.
- 3) Lower the closing tool onto the cover as shown in figure A.
- 4) Rotate the tool such that the eye of the lugs are positioned between the jaws of the closing tool as shown in Figure B.
- 5) **A) For pneumatic closing tool:** Depress both Humphrey Levers on top of Manifold and hold down. When tool completes downward motion, release levers.
B) For manual closing tool: Push out and down on handles until both handles come to stop.
- 6) Refer to Figure C and page 2 (Proper Pail Crimping) of this document to ensure integrity of the close. If necessary, a second crimping operation should be done by positioning the tool onto the pail such that the jaws of the tool are centered directly over the closed lug and repeating step 5.
- 7) Remove the closing tool. Lugs should be crimped under the curl of the pail at least 90° from their starting position. See Figure C or acceptable crimp on page 2 (Proper Pail Crimping).

Figure B



Figure A

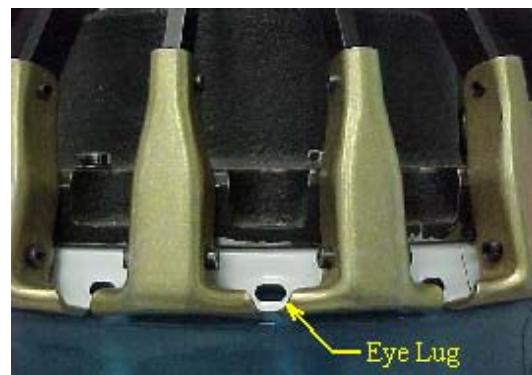

Figure C

Signature: 



Open Head Closing Instructions

CSC Form # QA-FM-251 Rev. 5 Date 6/10/04

Page 12

PROPER PAIL CRIMPING

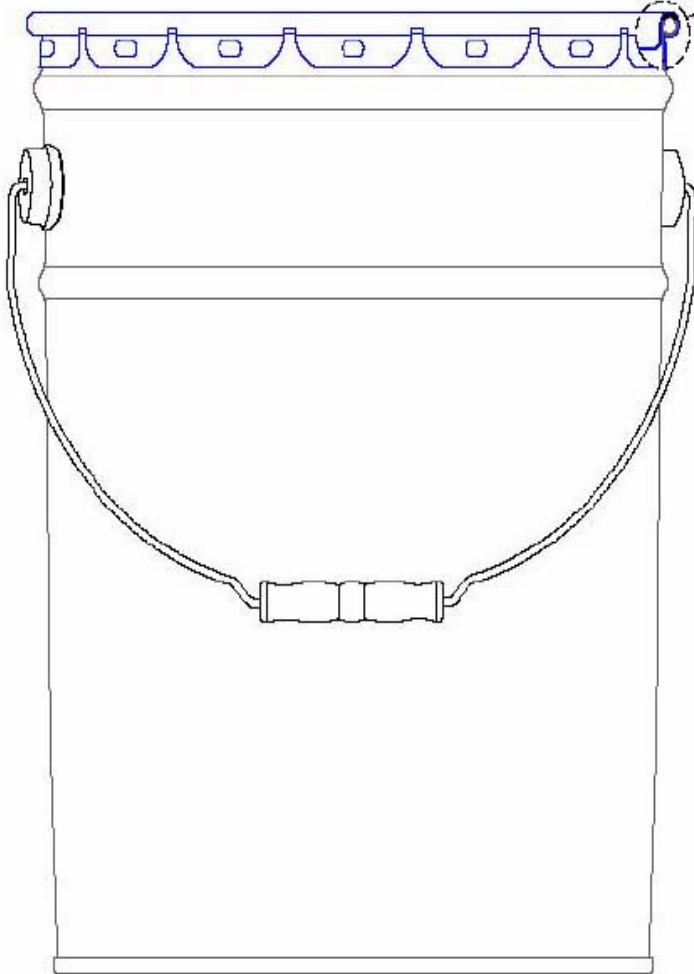

PREFERRED
CRIMP

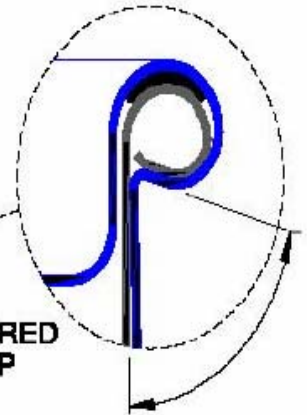

ACCEPTABLE
CRIMP

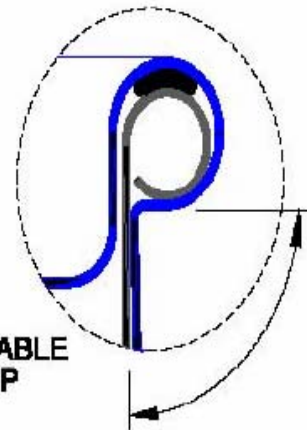

UNACCEPTABLE
CRIMP

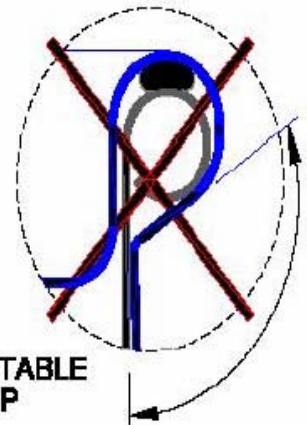



Rieke Tite-Grip and Vice-Grip Drum Fitting Closing Instructions

CSC Form # QA-FM-L255

Rev. 4

Date 10/20/10

Page 13

Manual Hand Tool:

- I. Place the fitting on the top of the container in the threaded opening.
- II. Start turning the fitting to the right, till the threads have started to engage.
- III. Finish installing the fitting with the manufacturers suggested wrench.
- IV. Make sure that the fitting is tightened to the proper specification. (see chart below.)

Pneumatic Hand Tool:

- I. Place the fitting on the top of the container in the threaded opening.
- II. Start turning the fitting to the right, till the threads have started to engage.
- III. Finish installing the fitting by using the pneumatic tool.
- IV. Make sure that the fitting is tightened to the proper specification. (see chart below.)

2" Plugs

<u>Gasket</u>	<u>Material</u>	<u>Plastic Plug</u>	<u>Steel Plug</u>	<u>Oven Temp</u>
G-43	Black Buna	20 ft-lbs	30 ft-lbs	450 F
G-43w	White Buna	20 ft-lbs	30 ft-lbs	450 F
G-73-2	L. D. Polyethylene	20 ft-lbs	30 ft-lbs	120 F
G-73-3	Irradiated L. D. Polyethylene	20 ft-lbs	30 ft-lbs	375 F
G-83	Dapon	20 ft-lbs	30 ft-lbs	450 F
G-93	E.P.T	20 ft-lbs	30 ft-lbs	450 F
G-93w	White EPT	20 ft-lbs	30 ft-lbs	450 F

3/4" Plugs

G-41	Black Buna	9 ft lbs	15 ft lbs	450 F
G-41w	White Buna	9 ft lbs	15 ft lbs	450 F
G-71-2	L. D. Polyethylene	9 ft lbs	15 ft lbs	120 F
G-71-3	Irradiated L. D. Polyethylene	9 ft lbs	15 ft lbs	375 F
G-81w	Dapon	9 ft lbs	15 ft lbs	450 F
G-91	E.P.T	9 ft lbs	15 ft lbs	450 F
G-91w	White EPT	9 ft lbs	15 ft lbs	450 F

Signature: _____



Rieke® FlexSpout® Closing Instructions

CSC Form # QA-FM-L253 Rev. 2 Date 08/07/02

Page 14

Manual Hand-Operated Application:

- 1) Place the container securely on a flat surface.
- 2) Place the Rieke FlexSpout in the opening at the top of the pail.
- 3) Use the Rieke Hand Crimping Tool (FS-600) to seal the FlexSpout to the opening.
- 4) Place the Rieke Hand Crimping Tool evenly over the fitting at the top of the container.
- 5) In the resting position, the handles of the tool should be at approximately a 45° angle to the top of the container.
- 6) Grip both handles with each hand and apply an even downward movement until the handles are in a position parallel with the top of the container.
- 7) It is important that the tool is resting evenly on the fitting when applying the crimp. A “cocking” or tilting of the tool will result in an improper seal and will cause leakage or contamination of the container’s contents.
- 8) A Rieke Gage (G101-1) can be used to check the crimp of the fitting to the pail. If a proper crimp was made, the gage should pass freely over the fitting.

Pneumatic / Semi-Automatic Application:

- 1) Place the container securely on a flat surface.
- 2) Place the FlexSpout in the opening at the top of the pail.
- 3) Use the Rieke Pneumatic Crimping Tool (IA-FS-600) to seal the FlexSpout to the opening.
- 4) Place the Rieke Pneumatic Crimping Tool evenly over the fitting at the top of the container.
- 5) It is important that the tool is resting evenly on the fitting when applying the crimp. A “cocking” or tilting of the tool will result in an improper seal and will cause leakage or contamination of the container’s contents.
- 6) A Rieke Gage (G101-1) can be used to check the crimp of the fitting to the pail. If a proper crimp was made, the gage should pass freely over the fitting.

Signature: _____



Screw Cap Closing Instructions

Manual Application:

- 1) Hold the container securely on a flat surface.
- 2) Place Innerseal over opening in nozzle. Apply pressure to Innerseal to ensure that it locks completely into the nozzle opening. ***Use caution to not distort innerseal while applying pressure.**
- 3) Place the Screw Cap over the opening in the nozzle. Gently turn the Screw Cap clockwise until the threads of the cap smoothly engage the threads of the nozzle.
- 4) Continue to turn the Screw Cap clockwise until the cap can no longer be torqued any tighter by hand. Using a torque wrench and specialized fitting for the size of the Screw Cap being applied, tighten the Screw Cap to no less than 80 inch-pounds. See table below for recommended torque specification in relation to Hydrostatic pressure rating marked on the container.

Automatic Application:

- 1) Set capping machine torque adjustment to varying specifications depending on product packaged. As a guide, the torque should be no less than 80 inch-pounds. See table below for recommended torque specification in relation to Hydrostatic pressure rating marked on the container.
- 2) Be alert for excessive misaligned or misthreaded caps, adjust alignment of cap and nozzle if necessary.

Recommended Torque Specifications for Screw Cap Fittings

Hydrostatic Pressure Rating	Torque
80 - 100 kPa	100 in-lbs.
< 80 kPa	80 in-lbs.

Signature: 



Tri-Sure Drum Fitting Closing Instructions

CSC Form # QA-FM-L256

Rev. 5

Date 10/20/10

Page 16

Manual Hand Tool:

- I. Place the fitting on the top of the container in the threaded opening.
- II. Start turning the fitting to the right, till the threads have started to engage.
- III. Finish installing the fitting with the manufacturers suggested wrench.
- IV. Make sure that the fitting is tightened to the proper specification. (see chart below.)

Pneumatic Hand Tool:

- I. Place the fitting on the top of the container in the threaded opening.
- II. Start turning the fitting to the right, till the threads have started to engage.
- III. Finish installing the fitting by using the pneumatic tool.
- IV. Make sure that the fitting is tightened to the proper specification. (see chart below.)

2" Plugs

<u>Gasket Material</u>	<u>Plastic Plug</u>	<u>Steel Plug</u>	<u>Oven Temp</u>
Black Buna	20 ft-lbs	30 ft-lbs	450 F
White Buna	20 ft-lbs	30 ft-lbs	450 F
Irradiated L. D. Polyethylene	20 ft-lbs	30 ft-lbs	375 F
L. D. Polyethylene	20 ft-lbs	30 ft-lbs	120 F
Dapon	20 ft-lbs	30 ft-lbs	450F
E.P.T	20 ft-lbs	30 ft-lbs	450 F
White EPT	20 ft-lbs	30 ft-lbs	450 F

3/4" Plugs

Black Buna	9 ft lbs	15 ft lbs	450 F
White Buna	9 ft lbs	15 ft lbs	450 F
Irradiated L. D. Polyethylene	9 ft lbs	15 ft lbs	375 F
L. D. Polyethylene	9 ft lbs	15 ft lbs	120 F
Dapon	9 ft lbs	15 ft lbs	450 F
E.P.T	9 ft lbs	15 ft lbs	450 F
White EPT	9 ft lbs	15 ft lbs	450 F

Signature: _____



Tri-Sure® UNI-GRIP® Spout Closing Instructions

CSC Form # QA-FM-L254 Rev. 2 Date 08/07/02

Page 17

Manual Hand-Operated Application:

- 1) Place the container securely on a flat surface.
- 2) Place the Tri-Sure Spout in the opening at the top of the pail.
- 3) Use the Tri-Sure Hand Crimping Tool to seal the Spout to the opening.
- 4) Place the Tri-Sure Hand Crimping Tool evenly over the fitting at the top of the container.
- 5) In the resting position, the handles of the tool should be at approximately a 45° angle to the top of the container.
- 6) Grip both handles with each hand and apply an even downward movement until the handles are in a position parallel with the top of the container.
- 7) It is important that the tool is resting evenly on the fitting when applying the crimp. A “cocking” or tilting of the tool will result in an improper seal and will cause leakage or contamination of the container’s contents.
- 8) A gage can be used to check the crimp of the fitting to the pail. If a proper crimp was made, the gage should pass freely over the fitting.

Pneumatic / Semi-Automatic Application:

- 1) Place the container securely on a flat surface.
- 2) Place the Tri-Sure Spout in the opening at the top of the pail.
- 3) Use the Tri-Sure Pneumatic Crimping Tool to seal the Spout to the opening.
- 4) Place the Tri-Sure Pneumatic Crimping Tool evenly over the fitting at the top of the container.
- 5) It is important that the tool is resting evenly on the fitting when applying the crimp. A “cocking” or tilting of the tool will result in an improper seal and will cause leakage or contamination of the container’s contents.
- 6) A gage can be used to check the crimp of the fitting to the pail. If a proper crimp was made, the gage should pass freely over the fitting.

Signature: _____



UNi-Pak Cradle Closing Instructions

CSC Form # QA-FM-L250

Rev. 5

Date 08/07/02

Page 18

- 1) Verify that the gasket is securely attached to the Cradle.
- 2) Position the cradle into the filled pail as shown.
- 3) Install the (1) gallon container horizontally into the Cradle.
- 4) Place the Hiperform Liner cover on top of the pail.
- 5) Position the closing tool on top of the Hiperform Liner cover. The jaws of the closing tool should be centered between the lugs. Apply downward pressure on the closing tool to ensure that the eye lugs are below the curl of the pail.
- 6) **For Automated / In-line Closing Tool:**
 - a) Check that the tool is centered evenly on top of the cover.
 - b) Once the crimping cycle is complete, verify that the lugs of the cover are completely tucked under the curl of the pail.

For Pneumatic Semi-Automatic Tool:

- a) Adjust the air pressure to the recommended 100psi. Connect the air line to the closing tool.
- b) Press and hold the actuator buttons until crimping operation is complete.
- c) Turn the closing tool 90° and repeat step b.
- d) Once the crimping cycle is complete, verify that the lugs of the cover are completely tucked under the curl of the pail.

Signature: _____

A handwritten signature in black ink, appearing to read "Michael J. De...".



UNi-Pak Cradle Closing Instructions

CSC Form # QA-FM-L250

Rev. 5

Date 08/07/02

Page 19

5. HYPERFORM LINER COVER →

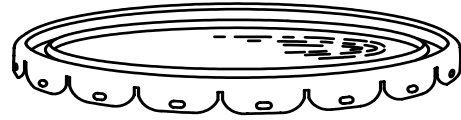

4. (1) GALLON CONTAINER →

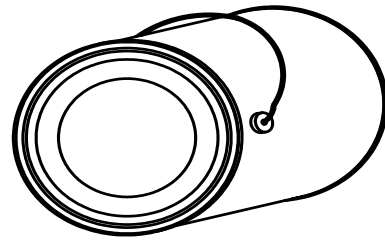

3. CRADLE →

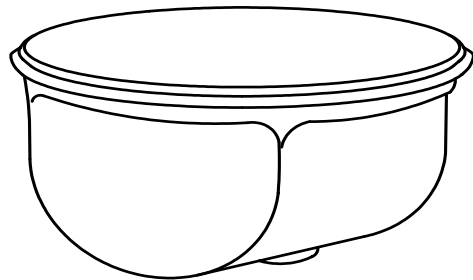

2. GASKET →

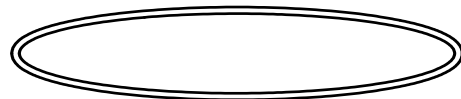

1. STEEL PAIL →

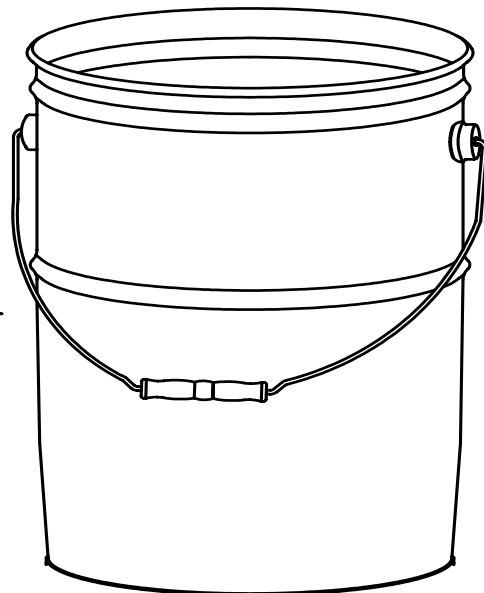



UNi-Pak Liner Closing Instructions

CSC Form # QA-FM-L273

Rev. 1

Date 10/15/02

Page 20

- 1) Position the liner into the empty pail as shown.
- 2) Fill liner/pail with designated material.
- 3) A polyethylene or compatible sheet liner may be placed (if desired), over the opening at the top of the pail. Be sure to center the sheet liner, so that it covers the entire opening.
***Note:** Using the polyethylene sheet liner will make the package ineligible for air transport due to performance limitations on the hydrostatic pressure test.
- 4) Place the Hiperform Liner cover on top of the pail.
- 5) Position the closing tool on top of the Hiperform Liner cover. The jaws of the closing tool should be centered between the lugs. Apply downward pressure on the closing tool to ensure that the eye lugs are below the curl of the pail.
- 6) **For Automated / In-line Closing Tool:**
 - a) Check that the tool is centered evenly on top of the cover.
 - b) Once the crimping cycle is complete, verify that the lugs of the cover are completely tucked under the curl of the pail.

For Pneumatic Semi-Automatic Tool:

- a) Adjust the air pressure to the recommended 100psi. Connect the air line to the closing tool.
- b) Press and hold the actuator buttons until crimping operation is complete.
- c) Turn the closing tool 90° and repeat step b.
- d) Once the crimping cycle is complete, verify that the lugs of the cover are completely tucked under the curl of the pail.

Signature: _____

A handwritten signature in black ink, appearing to read "Michael J. De...".



UNi-Pak Liner Closing Instructions

CSC Form # QA-FM-L273

Rev. 1

Date 10/15/02

Page 21

4. HYPERFORM LINER COVER

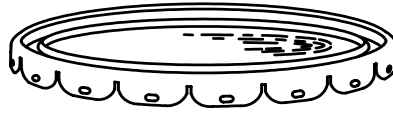

3. SHEET LINER (OPTIONAL)

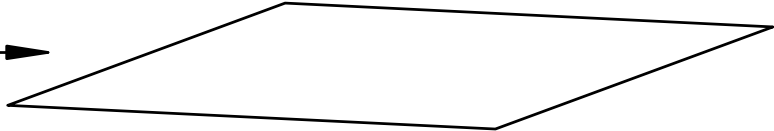
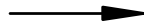

2. PAIL LINER

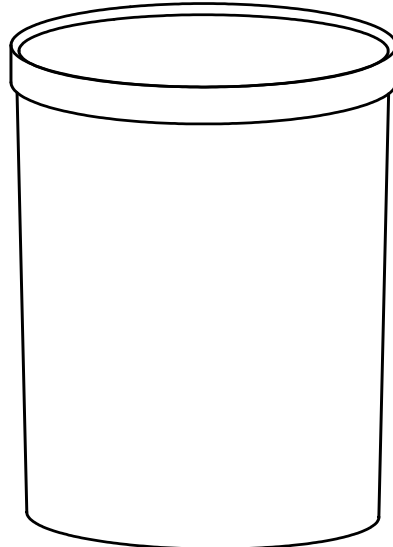

1. STEEL OVERPACK (PAIL)

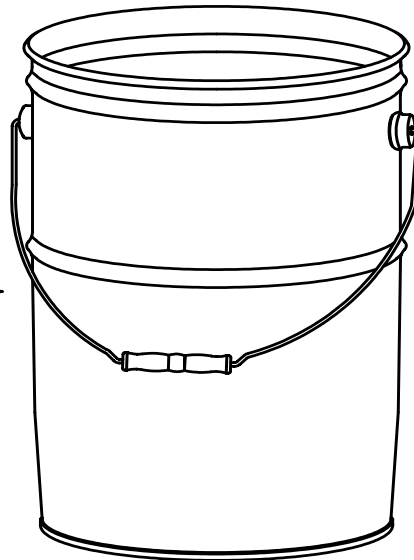



UNi-Pak Tray w/ Scholle Bag Closing Instructions

CSC Form # QA-FM-L266

Rev. 3

Date 08/07/02

Page 22

- 1) Verify that the gasket is securely attached to the Tray.
- 2) Position the tray into the filled pail as shown.
- 3) Install the filled 2-Ply Scholle bag horizontally into the tray with fitting upright.
- 4) Place the Hiperform Liner cover on top of the pail.
- 5) Position the closing tool on top of the Hiperform Liner cover. The jaws of the closing tool should be centered between the lugs. Apply downward pressure on the closing tool to ensure that the eye lugs are below the curl of the pail.
- 6) **For Automated / In-line Closing Tool:**
 - a) Check that the tool is centered evenly on top of the cover.
 - b) Once the crimping cycle is complete, verify that the lugs of the cover are completely tucked under the curl of the pail.

For Pneumatic Semi-Automatic Tool:

- a) Adjust the air pressure to the recommended 100psi. Connect the air line to the closing tool.
- b) Press and hold the actuator buttons until crimping operation is complete.
- c) Turn the closing tool 90° and repeat step b.
- d) Once the crimping cycle is complete, verify that the lugs of the cover are completely tucked under the curl of the pail.

Signature: _____

A handwritten signature in black ink, appearing to read "Michael J. De...".



UNi-Pak Tray w/ Scholle Bag Closing Instructions

CSC Form # QA-FM-L266

Rev. 3

Date 08/07/02

Page 23

4. HYPERFORM LINER COVER →

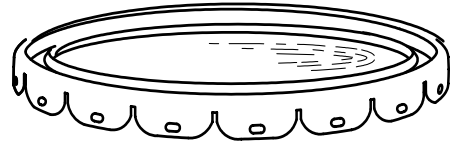

4. 2-PLY SCHOLLE BAG →

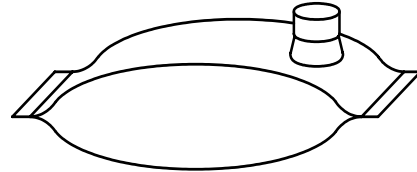

3. TRAY →

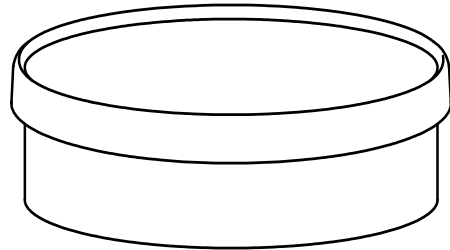

2. GASKET →

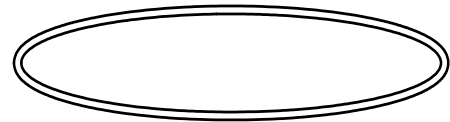

1. STEEL OVERPACK (PAIL) →

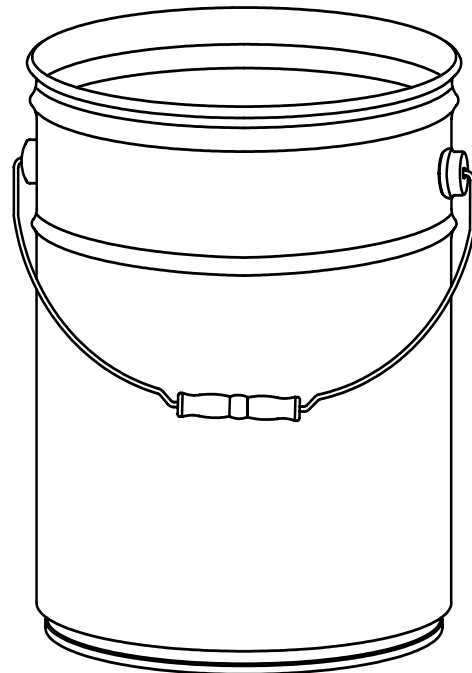



UNi-Pak Tray Closing Instructions

CSC Form # QA-FM-L267

Rev. 2

Date 08/07/02

Page 24

- 1) Verify that the gasket is securely attached to the Tray.
- 2) Position the tray into the filled pail as shown.
- 3) Fill Tray with designated material.
- 4) Place the Hiperform Liner cover on top of the pail.
- 5) Position the closing tool on top of the Hiperform Liner cover. The jaws of the closing tool should be centered between the lugs. Apply downward pressure on the closing tool to ensure that the eye lugs are below the curl of the pail.
- 6) **For Automated / In-line Closing Tool:**
 - a) Check that the tool is centered evenly on top of the cover.
 - b) Once the crimping cycle is complete, verify that the lugs of the cover are completely tucked under the curl of the pail.

For Pneumatic Semi-Automatic Tool:

- a) Adjust the air pressure to the recommended 100psi. Connect the air line to the closing tool.
- b) Press and hold the actuator buttons until crimping operation is complete.
- c) Turn the closing tool 90° and repeat step b.
- d) Once the crimping cycle is complete, verify that the lugs of the cover are completely tucked under the curl of the pail.

Signature: _____

A handwritten signature in black ink, appearing to read "Michael J. De...". The signature is written over a horizontal line.



UNi-Pak Tray Closing Instructions

CSC Form # QA-FM-L267

Rev. 2

Date 08/07/02

Page 25

4. HYPERFORM LINER COVER →

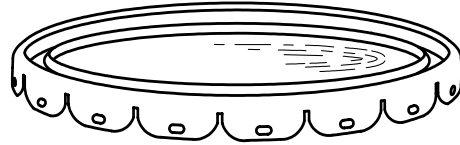

3. TRAY →

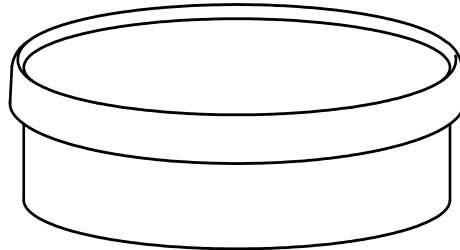

2. GASKET →



1. STEEL OVERPACK (PAIL) →

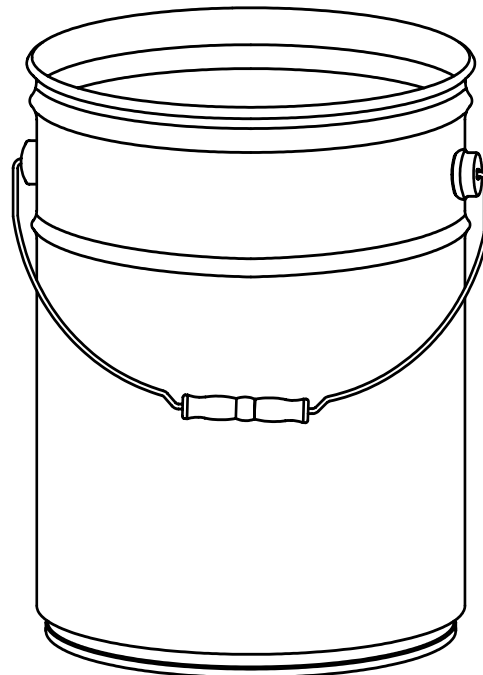



Stolz HZ60 Screw Cap Closing Instructions

CSC Form # QA-FM-L274 Rev. 0

Date 6/30/07

Page 26

- 1) Place the Stolz cap over the opening in the nozzle. Gently turn the cap clockwise until the threads of the cap smoothly engage the threads of the nozzle.
- 2) Continue to turn the Screw Cap clockwise until the tab on the cap clicks past the stop on the nozzle and the cap can no longer be torqued any tighter by hand.

** Please see printed instructions on top of cap.



Signature: _____

Michael A. De...



LeverLock(RU-1) Closing Instructions

Form# QA-FM-L275

Rev. 1

Date: 12/07/09

Page 27

Proper Application of the RU-1 LeverLock Ring to the Pail

1. First place the cover on the pail and press downward along the edges and in the center to ensure that it is seated properly. **See Figure 1.**
2. Open leverlock ring to widest margin, then slip ring over pail. Be sure that the ring is placed on the pail such that it can be closed by moving the lever clockwise onto the ring. **See Figure 2.**
3. Orient the lever on the ring opposite the side seam of the pail or at 180° from the side seam.
4. Apply downward pressure to the cover and release the lever allowing the ring to slide onto the cover/curl edge. Be sure that the ring encompasses the cover/curl around the entire edge of the pail. **See Figure 3.**
5. Close the ring clockwise by applying pressure to the lever until it collapses onto the ring, as in **Figure 4.**
6. Push the latch that is attached to the ring body through the slot in the lever to hold the lever in place. The latch should snap into place. **See Figure 5.**
*** A locking mechanism may be inserted into the eyelet of the latch to make tamper-evident.**
7. After it is locked, the ring should not be able to be rotated or moved. Any sliding of the ring could indicate an oversized ring.



Fig. 1



Fig. 2



Fig. 3



Fig. 4



Fig. 5

Signature: _____

Michael S. De...